

## Cooling & Heating



**Efficlean**<sup>TM</sup>

**Intelligent Oil Filtration System**

*Ensuring oil quality, reducing waste and keeping the environment clean*

## Improving your business is our business

Thermax offers products, systems and solutions in energy and environment engineering to industrial and commercial establishments around the world. Its business expertise covers heating, cooling, waste heat recovery, captive power, water treatment & recycling, air pollution control & waste management and performance chemicals. Thermax brings to customers extensive experience in industrial applications, and expertise through technology partnerships and strategic alliances.

Operating from its headquarters in Pune (Western India), Thermax has built an international sales & service network spread over South East Asia, Middle East, Africa, Russia, UK and the US. It has a full fledged manufacturing set up that is certified for ISO 9001:2000, ISO 14001 and safety management according to OSHAS (ISO 18000).

In **process heat**, Thermax offers a wide range of steam boilers, thermal oil heaters and hot water generators. It has expertise in a wide range of fuels - oil, gas, solid and agro-waste/ biomass.

Supporting a broad array of industries in generating, transferring and conserving heat across a host of applications, Thermax process heat products and systems are exported to North and South America, South East Asia, Middle East, Africa, Europe, CIS, Australia, Antarctica and SAARC.

## Impurities in oil

With increasing frequency, utility owners and operators are experiencing a significantly increased need for oil handling and treatment requirement.

Any boiler's capability to burn commercial grades of Heavy Fuel Oil is dependent on the fuel characteristics and the level of contaminants in the fuel. As fuel grade and quality decrease, the resultant impact on the burner's operating reliability and economics will be strongly influenced by the ability of fuel handling systems available to provide properly treated fuel.

Insolubles in the Thermic fluid can cause havoc with the performance of the system, even leading to choking of the complete system. This is one of the major reasons for discontinuing the use of Thermic fluid - the presence of percentage insolubles of more than 1%.

## Problems with heavy fuel oil combustion systems

- Maximum particle size going into the system for combustion would be 125 microns, which would be the maximum for a 120 mesh filter can screen. The particles below 125 micron are the main cause of wear of burner nozzles in, thus causing decrease in combustion efficiency.
- Analysis shows that a maximum percentage of impurities in sediments are in the range of 0.25 to 100 microns, which is way below the capacity of any normal mesh filtration system.
- Due to routine maintenance required for cleaning, large number of man hours spent on this activity.
- Wastage of dirty oil from strainers every time filter is cleaned - this is a direct loss of expensive furnace oil.
- Use of diesel is required for cleaning filter elements.
- Nozzle failures arising from improper oil quality.
- Frequent pump failures as a result of high wear and tear.

## Advantages of using Efficlean filtration system for Furnace Oil

- Higher availability of system.
- Lesser pump and nozzle failures.
- Reduced draining of costly Furnace Oil.
- Reduced frequency of cleaning of nozzles and filters.
- By pass filtration - does not affect operation of the system.
- Prevents highly abrasive particles like Silica, Aluminium etc. from causing irreparable damage to system.
- Enhances system capability to perform at maximum efficiency for prolonged periods of time.

## Advantages of using Efficlean filtration system for thermic fluid

- Prevent insolubles from choking the system.
- Improve the heat transfer rate by reducing scale formation.
- Reduce pumping costs.

## What is Efficlean

- Efficlean is a filter that separates solid from liquid at micron levels, even to the extent of 0.25 microns.
- Works on the principle of centrifugal action, where oil will be circulated for a predefined number of passes as recommended, and cleaned oil sent back to the tank.
- This is a bypass filter, with a separate pump for inlet pressure requirements of 2.5 to 7.0 bar depending on medium to be filtered.
- This pressure energy is converted to rotational energy in Efficlean, which causes particles to accumulate layer by layer in the rotor walls.
- Cleaned oil from Efficlean is routed back to the tank by gravitational forces.

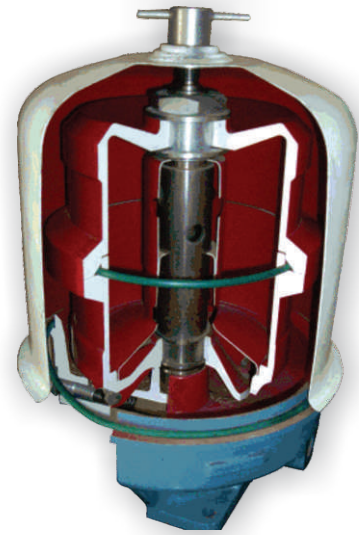

## Working principle

- The design uses pressure energy of 6 bar of fluid to rotate the unit at speeds of 4000 - 6000 rpm.
- This centrifugal force separates solid from liquid, where solid impurities stick to the wall of the centrifuge and the liquid falls into sump/ tank due to gravity.
- This solid muck is cleaned out by stopping the centrifuge, cleaning particles to as low as 0.25 microns from the medium.

## Efficlean at work

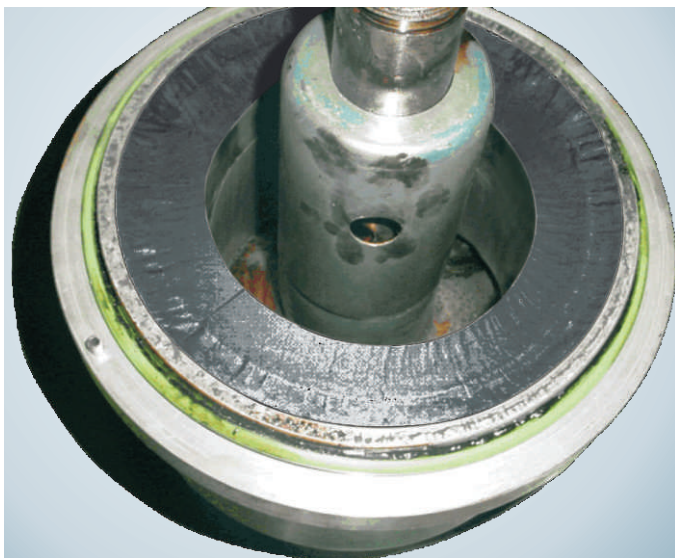

- Ensure oil quality.
- Ensure better system operation.
- Ensure prevention of oil sticking to walls and choking orifices.
- Ensure system is kept free from abrasive particles.
- Ensure that adulteration does not cause wearing out and damage of high value mechanical components.
- Ensure optimum efficiencies for maximum durations.

## Models available

Model	Efficlean F/T 6.0	Efficlean F/T 2.0
Rotor dirt capacity	6.0 ltr	2.0 ltr
Rotor oil capacity	6.5 ltr	2.3 ltr
Weight of filter	25 kg	9.5 kg
Cleaning frequency	1KL for 1 hr. circulation	1KL for 4 hr. circulation

## Scope of supply

- Efficlean centrifugal oil filter
- Isolation ball valves
- Strainer
- Suitable pump with motor
- Pressure gauge
- Pressure regulating valve

## Schematic diagram

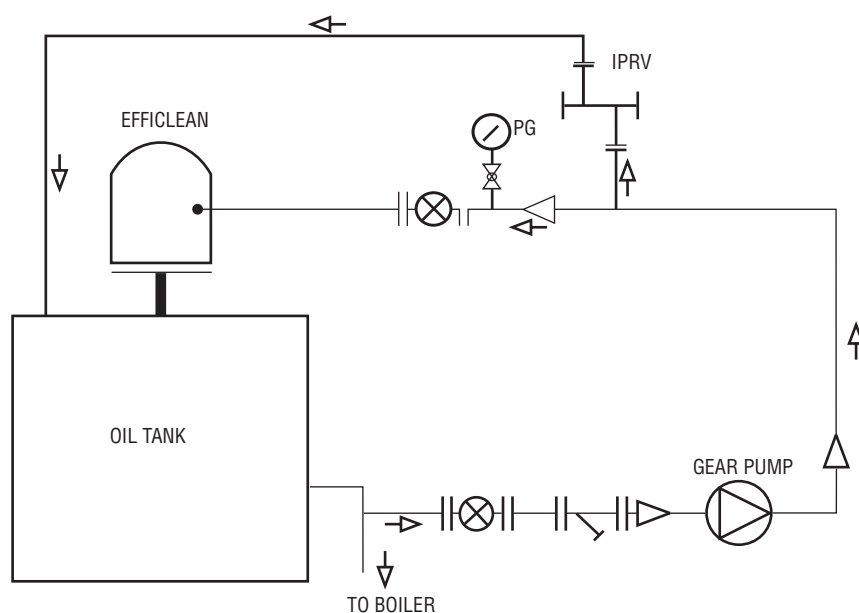

## Eco-friendly solution

With environmental awareness growing nationwide, safe and efficient waste disposal is the need of the hour. Which is why the Efficlean system is the perfect answer as it eliminates the use of disposable paper elements. Also, since no consumables are used in this filtration system, hence no repeat costs to customers.

*In view of our constant endeavour to improve the quality of our products, we reserve the right to alter or change specifications without prior notice. All photographs shown in this publication are representative in purpose, and to be used for reference only. For actual details and specifications, please refer to Thermax offer document.*



**THERMAX**

Sustainable Solutions in  
Energy & Environment

### COOLING & HEATING DIVISION Services SBU

D - 13, MIDC Industrial Area, R. D. Aga Road,  
Chinchwad, Pune 411 019. INDIA  
Tel. : +91-20-2747 5941  
Fax : +91-20-2747 7080  
E-mail : info.c&hservices@thermaxindia.com

#### AHMEDABAD 380 006

Tel. : (079) 2657 5408 / 5341 / 7073  
Fax : (079) 2657 7270  
E-mail : mambiar@thermaxindia.com

#### BANGALORE 560 020

Tel. : (080) 2346 7761 - 64  
Fax : (080) 2346 7760  
E-mail : adminblr@thermaxindia.com

#### CHENNAI 600 018

Tel. : (044) 2435 3831 - 34  
Fax : (044) 2435 3841  
E-mail : chennaidivsupp@thermaxindia.com

#### HYDERABAD 500 482

Tel. : (040) 2339 6820, 2331 0254  
Fax : (040) 2331 2335  
E-mail : hyd\_sec@thermaxindia.com

#### MUMBAI 400 016

Tel. : (022) 2204 5391, 2204 5324  
Fax : (022) 2204 0859  
E-mail : psecretat@thermaxindia.com

#### NEW DELHI 110 057

Tel. : (011) 2614 5319, 2614 5701  
Fax : (011) 2614 5311, 2614 8679  
E-mail : psupport@thermaxindia.com

#### KOLKATA 700 017

Tel. : (033) 2282 6711 - 13  
Fax : (033) 2282 6796  
E-mail : mbiswas@thermaxindia.com

#### International Offices:

##### MIDDLE EAST (DUBAI)

Tel: +9714-8861424; E-mail:  
info@thermaxdubai.ae

##### SOUTH EAST ASIA (MALAYSIA)

Tel: +60127798493  
Email: thermax@tm.net.my

##### HO, AFRICA, SAARC & OTHER COUNTRIES

Tel: +91-20-66128802/8818/8845  
Email: info.c&hservices@thermaxindia.com

#### International offices:

Indonesia, Russia, Kazakstan, Saudi Arabia,  
Bangladesh, Sri Lanka, Hong Kong, China,  
Thailand, Malaysia, Philippines, UAE, Kenya,  
Nigeria, Brazil, UK, USA

## Thermax Business Portfolio

Boilers & Heaters

Absorption Cooling

Air Pollution Control

Captive Power

Chemicals

Water & Waste Solutions